

Trouble Shooting | Twin 160-202 Ultra - Twin AP160-AP202 Ultra

Trouble Shooting	Possible cause	Correction
SPRINKLER DOES NOT START UP 1, 2, 4, 5, 9	1 Nozzle damaged	Replace nozzle
SPRINKLER STOPS 1, 2, 3, 4, 5, 6, 9, 10	2 Deflector damaged	Replace kit deflector
SPRINKLER ROTATES SLOWLY 1, 2, 3, 4, 5, 8, 9, 10	3 Brake System assembly rotation hard/seized	Replace kit brake/seals
SPRINKLER DOES NOT INVERT 1, 2, 4, 5, 6, 7, 9	4 Poor system pressure	Check pressure, elevation change, booster pump
SPRINKLER THROW SHORTENED 1, 4, 9	5 Drive arm hindered in its movement	Diassemble and check for wear parts and debris
	6 Trip spring damaged	Replace kit trip springs
	7 Trip stop ring out of its grooves	Position trip stop ring correctly
	8 Speed selector in wrong position	Adjust speed selector correctly
	9 Sprinkler partially/totally plugged	Check inside of gun to be free of debris
	10 Sloping terrain	Install counterweight

Fehlersuche	Mögliche Ursachen	Abhilfe
REGNER STARTET NICHT 1, 2, 4, 5, 9	1 Düse beschädigt	Düse erneuern
REGNER BLEIBT STEHEN 1, 2, 3, 4, 5, 6, 9, 10	2 Deflektor beschädigt	Kit Deflektor erneuern
REGNER DREHT LANGSAM 1, 2, 3, 4, 5, 8, 9, 10	3 Bremssystem dreht nicht oder schwer	Kit Bremse/Dichtungen erneuern
REGNER WENDET NICHT 1, 2, 4, 5, 6, 7, 9	4 Betriebsdruck zu niedrig	Druck, Höhenunterschied, Druckerhöhungspumpe kontrollieren
WURFWEITE VERKÜRZT 1, 4, 9	5 Schwingarm in seiner Bewegung nicht frei	Abbauen und auf Verschleiß und Schmutz kontrollieren
	6 Sektorfeder beschädigt	Kit Sektorfeder erneuern
	7 Sektoring nicht in seiner Nut positioniert	Sektoring in seine Nut geben
	8 Geschwindigkeitsregulierung falsch	Geschwindigkeitsregulierung richtig einstellen
	9 Regner teilweise oder zur Gänze verstopft	Regner innen auf freien Durchfluss kontrollieren
	10 Hanglage	Gegengewicht montieren

Ricerca Guasti	Probabile causa	Rimedio
L'IRRIGATORE NON PARTE 1, 2, 4, 5, 9	1 Ugello danneggiato	Sostituire l'ugello
L'IRRIGATORE SI FERMA 1, 2, 3, 4, 5, 6, 9, 10	2 Deflettore danneggiato	Sostituire il kit deflettore
L'IRRIGATORE GIRA LENTO 1, 2, 3, 4, 5, 8, 9, 10	3 Rotazione lenta/bloccata del sistema freno	Sostituire il kit freno e/o guarnizioni
L'IRRIGATORE NON INVERTE 1, 2, 4, 5, 6, 7, 9	4 Pressione d'esercizio insufficiente	Controllare pressione, dislivello e pompa di rilancio
LA GITTATA È RIDOTTA 1, 4, 9	5 Braccio oscillante legato nel suo movimento	Smontare e controllare per usura e/o corpi estranei
	6 Molla scatto settore danneggiata	Sostituire il kit molla scatto settore
	7 Anello settore posizionato fuori dalla sua sede	Posizionare correttamente l'anello settore
	8 Selettore velocità regolato in posizione non corretta	Regolare correttamente la velocità
	9 Irrigatore parzialmente/totalmente otturato	Liberare l'interno dell'irrigatore da possibili detriti
	10 Terreno con pendenza	Installare un contrappeso

Aide au Dépannage	Cause possible	Remède
L'ARROSEUR NE DÉMARRE PAR 1, 2, 4, 5, 9	1 Buse endommagée	Remplacer la buse
L'ARROSEUR S'ARRÊTE 1, 2, 3, 4, 5, 6, 9, 10	2 Déflecteur endommagé	Remplacer le kit déflecteur
L'ARROSEUR TOURNE LENTEMENT 1, 2, 3, 4, 5, 8, 9, 10	3 La rotation du système de frein est bloquée/dure	Remplacer le kit frein/joints
L'ARROSEUR NE S'INVERSE PAS 1, 2, 4, 5, 6, 7, 9	4 Pression système insuffisante	Vérifier la pression du système, le dénivelé, le surpresseur
LA PORTÉE EST RÉDUITE 1, 4, 9	5 Le bras oscillant est entravé dans son mouvement	Démonter et rechercher pièces usées et/ou débris
	6 Ressort inversion endommagé	Remplacer le kit ressort inversion
	7 Anneau secteur hors de son siège	Positionner correctement l'anneau secteur
	8 Régulateur vitesse mal positionné	Régler correctement la vitesse
	9 Arroseur partiellement/complètement bouché	Vérifier que l'intérieur du canon ne contient aucun débris
	10 Terrain en pente	Installer un contrepoids

Detección de Fallos	Posibles causas	Corrección
EL ASPERSOR NO ARRANCA 1, 2, 4, 5, 9	1 Boquilla dañada	Sustituir la boquilla
EL ASPERSOR SE DETIENE 1, 2, 3, 4, 5, 6, 9, 10	2 Deflector dañado	Sustituir el kit deflector
EL ASPERSOR ROTA LENTAMENTE 1, 2, 3, 4, 5, 8, 9, 10	3 Rotación del sistema del freno lenta/bloqueado	Sustituir el kit de freno/guarnición
EL ASPERSOR NO INVIERTE 1, 2, 4, 5, 6, 7, 9	4 Presión de servicio insuficiente	Controlar presión, diferencia de nivel, rebombeo
ALCANCE REDUCIDO 1, 4, 9	5 Brazo oscilante obstaculizado en su movimiento	Desmontar y controlar si hay desgaste o suciedad
	6 Muelle sector dañado	Sustituir el kit muelle sector
	7 Anillo sector fuera de su ranura	Posicionar el muelle sector en su ranura
	8 Selector de velocidad en posición incorrecta	Regular correctamente la velocidad
	9 Aspersor parcialmente/totalmente obstruido	Comprobar que el interior del aspersor esté libre de residuos
	10 Terreno en pendiente	Instalar contrapeso

Identificação de Defeitos	Causa possível	Solução
O ASPERSOR NÃO ARRANCA 1, 2, 4, 5, 9	1 Bocal danificado	Substituir o bocal
O ASPERSOR PÁRA 1, 2, 3, 4, 5, 6, 9, 10	2 Defletor danificado	Substituir o kit defletor
O ASPERSOR ROTA LENTAMENTE 1, 2, 3, 4, 5, 8, 9, 10	3 Rotação sistema do freio endurecido/agarrado	Substituir kit de freio/guarnição
O ASPERSOR NÃO INVERTE 1, 2, 4, 5, 6, 7, 9	4 Pressão do sistema insuficiente	Verificar o pressão do sistema, elevação e bomba de reforço
O ASPERSOR COM JATO REDUZIDO 1, 4, 9	5 Braço oscilante travado em seu movimento	Desmontar e verificar se há peças desgastadas e/ou detritos
	6 Mola de setor danificado	Substituir kit mola de setor
	7 Anel de setor fora de seu alojamento	Posicionar corretamente o anel nos sulcos
	8 Seletor de velocidade na posição errada	Ajuste o seletor de velocidade corretamente
	9 Aspersor parcialmente/totalmente entupido	Verificar que ao interno do canhão esteja livre de detritos
	10 Terrenos inclinados	Instale contrapeso

Never service the gun while in operation.

Niemals während des Betriebes Einstellungen/Wartungen am Regner durchführen.

Non eseguire operazioni sull'apparecchio in funzione.

Ne pas faire d'interventions sur le canon en marche.

Nunca efectuar trabajos sobre el cañon en marcha.

Nunca execute operações com o canhão em marcha.

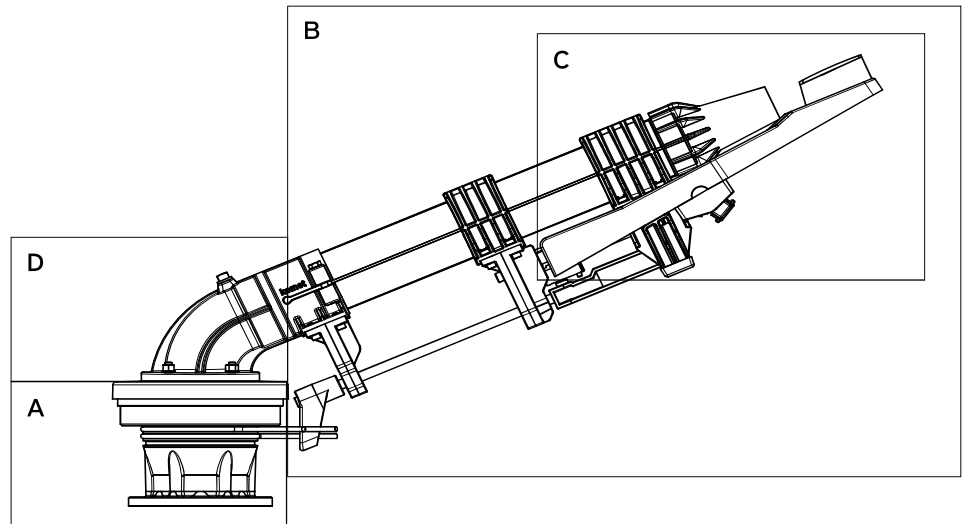

INSTRUCTIONS:

1. All moving parts have to be free.
2. When greasing, use a soft, water resistant quality grease brand.
3. The brake surfaces should never come in contact with grease.
4. If parts have to be replaced, use the Assemblies or Kits as shown in the spare parts list, this assures a simple and complete service. For replacement follow the sequence as shown hereafter.
5. For trouble shooting it is advantageous to have the spare parts list on hand.

ANLEITUNG:

1. Alle Bewegungen müssen frei und leichtgängig sein.
2. Zum Fetten, ein weiches, wasserfestes Fett verwenden.
3. Die Bremsscheiben dürfen niemals mit Fett in Berührung kommen.
4. Beim Austauschen von Teilen sich der Teile-Sätze wie aus der Ersatzteil-Liste hervorgeht (fett gedrückt) bedienen, dadurch ist eine einfache und umfassende Erneuerung gewährleistet. Für den Zusammenbau, die abgebildeten Sequenzen zur Demontage in umgekehrter Reihenfolge ausführen.
5. Bei der Fehlersuche ist es vorteilhaft, die dem Regner beigelegte Ersatzteil-Liste zur Hand zu haben.

ISTRUZIONI:

1. Tutti i movimenti devono essere liberi.
2. Per ingrassare usare un grasso di marca, morbido e resistente all'acqua.
3. Le pastiglie freno non devono venire assolutamente a contatto con grasso.
4. Nella sostituzione di particolari, servirsi del Kit ricambio preconfezionati come indicati nella lista ricambi (neretto), questo assicura un semplice e completo ripristino. Per il montaggio seguire a ritroso le sequenze di smontaggio illustrate.
5. Per la ricerca guasti è utile avere a disposizione la lista ricambi in dotazione all'apparecchio.

INSTRUCTIONS:

1. Toutes les parties articulées doivent se mouvoir librement.
2. Pour graisser, utiliser une bonne graisse molle, résistante à l'eau.
3. Les pastilles frein ne doivent jamais entrer en contact avec la graisse.
4. S'il faut remplacer des pièces, utiliser les kits de rechange, indiqués en gras sur la liste des pièces de rechange, ceci garantit une manutention complète et simple. Pour le montage, suivre à rebours les séquences de démontage illustrées.
5. Pour la recherche des pannes, nous conseillons d'avoir à portée de la main la liste des pièces de rechange fournie avec l'arroseur.

INSTRUCCIONES:





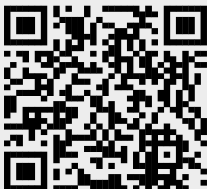

1. Todos los movimientos deben ser libres.
2. Para un correcto mantenimiento, usar grasa de calidad de poca densidad (fluida).
3. Las pastillas de freno no deben estar nunca en contacto con grasa.
4. Si debe cambiarse alguna pieza, utilizar los kits de recambios confeccionados que figuran en el catálogo piezas, lo cual garantiza una sencilla y completa reparación. Para el montaje, ver esquemas adjuntos.
5. Para la busca de los desperfectos, aconsejase de tener al alcance de la mano la lista de recambios facilitada con el aspersor.

INSTRUÇÕES:

1. Todos os movimentos devem estar livres.
2. Para lubrificação, usar somente graxa de baixa densidade (fluida) e resistente à água.
3. As pastilhas do freio jamais deverão entrar em contacto com a graxa.
4. Se houver necessidade de reposição de peças, utilizar os conjuntos apresentados no catálogo de peças, esse procedimento garante uma manutenção simples e completa. Seguir os procedimentos de montagem e desmontagem apresentados a seguir.
5. Para a identificação de defeitos, é recomendável manter-se a lista de peças de reposição à mão.

 **YouTube**
Service & Troubleshooting



Tools Werkzeuge Utensili Outils Herramientas Ferramentas	6 mm 	8 mm 	
	5 mm 	Nut driver / Steckschlüssel Chiave per bussola / Clé à pipe Llave de enchufe / Chave soquete	
	Hex wrench / Sechskantschlüssel Chiave per brugola / Clé allen Llave hexagonal / Chave allen		
	13 mm 	Flat screwdriver, small Kleiner Schraubenzieher, flach Cacciavite piccolo, piatto Petit tournevis plat Destornillador plano, pequeño Chave de fenda pequena	
	Open end wrench / Gabelschlüssel Chiave a forchetta / Clé plate Llave de boca / Chave inglesa	Nozzle wrench Düsenschlüssel Chiave bocaglio Clé pour buse Llave-boquilla Chave para bocal	

A

Bearing
 Hauptlager
 Corpo Cuscinetto
 Corps Roulement
 Cuerpo Cojinete
 Conjunto Rolamento

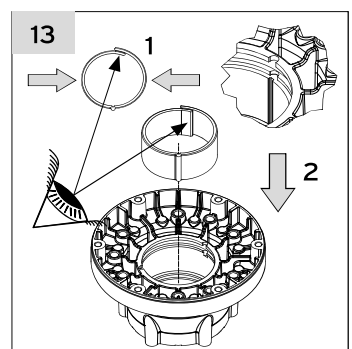
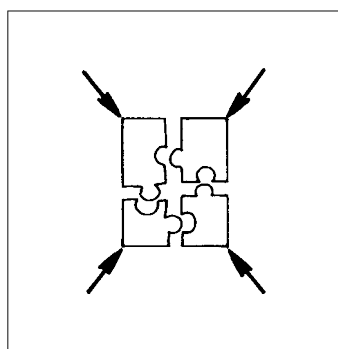
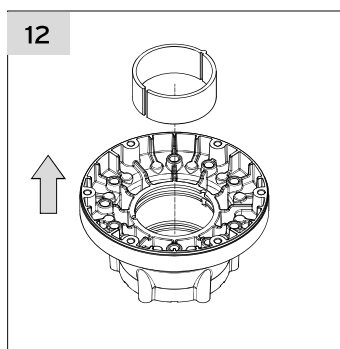
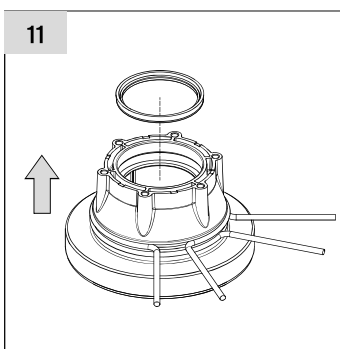
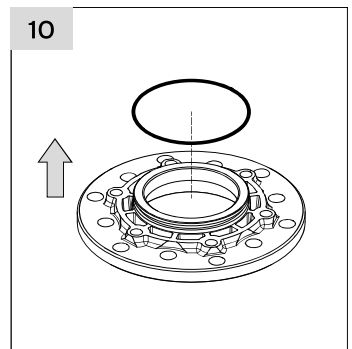
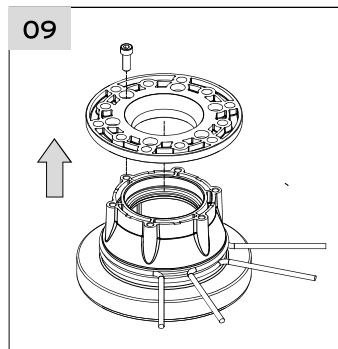
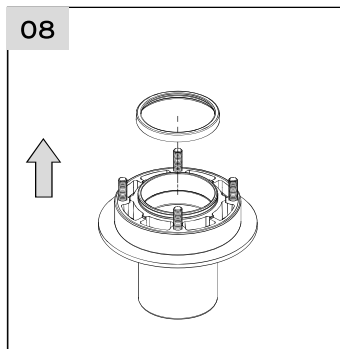
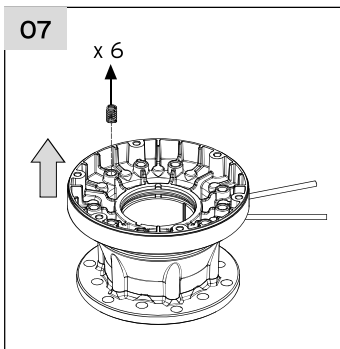
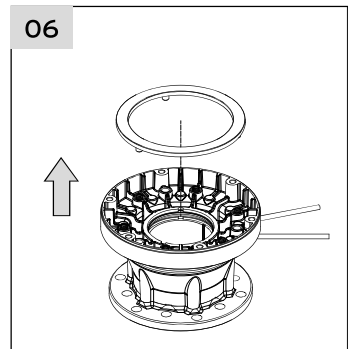
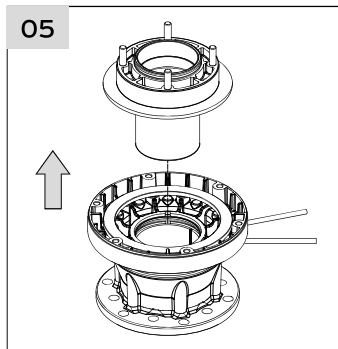
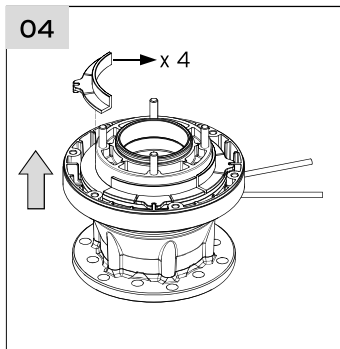
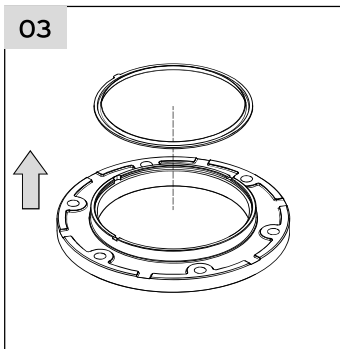
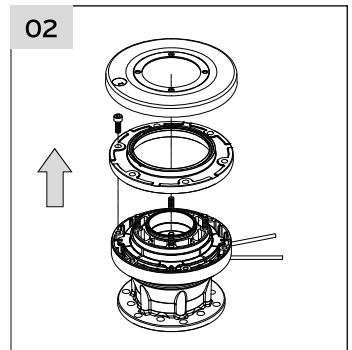
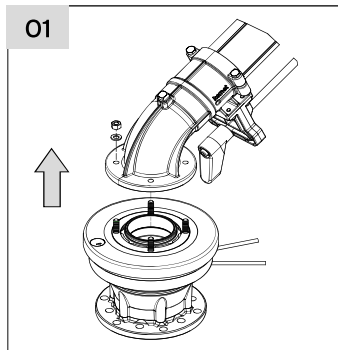
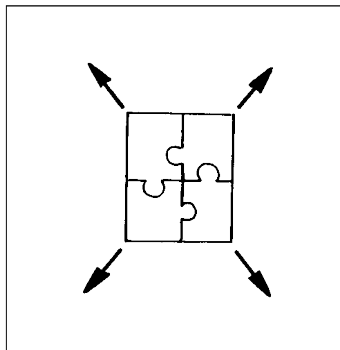

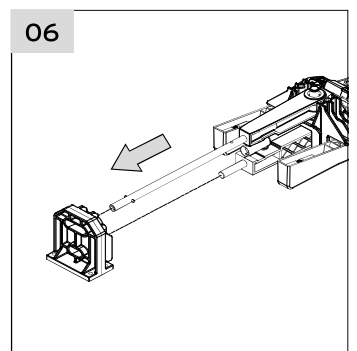
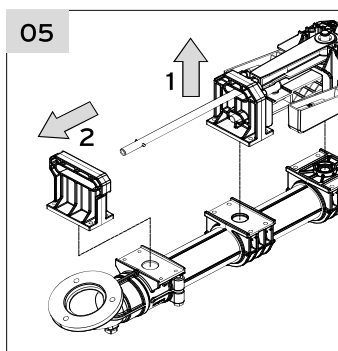
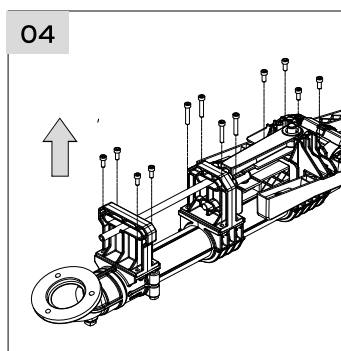
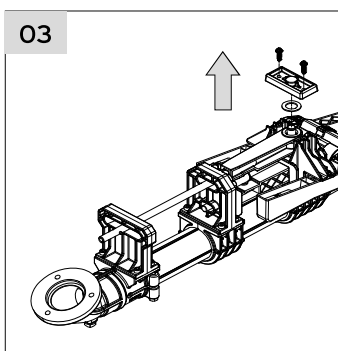
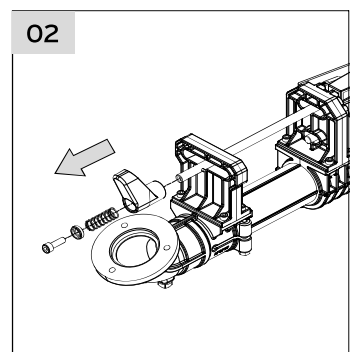
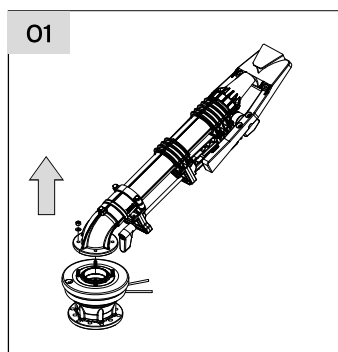
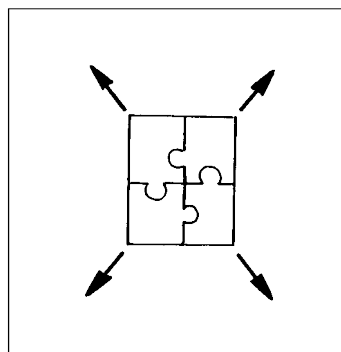
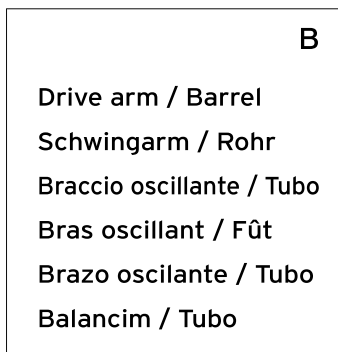
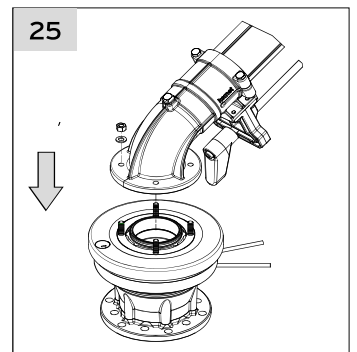
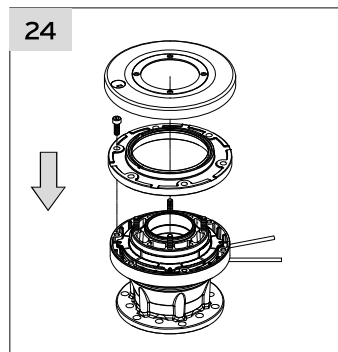
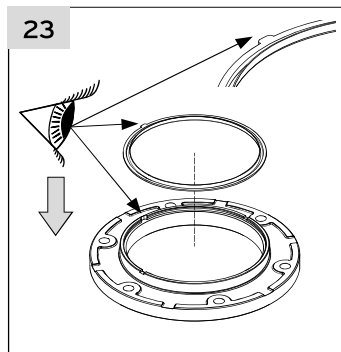
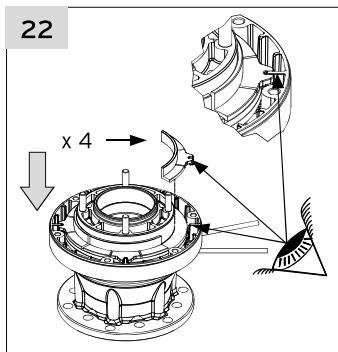
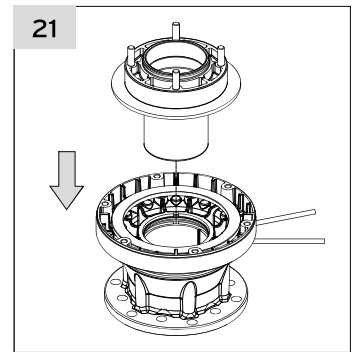
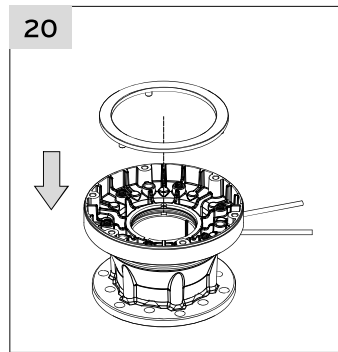
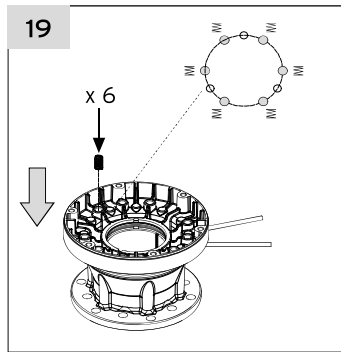
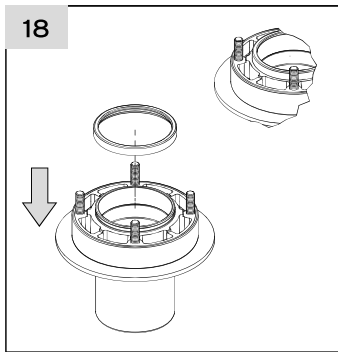
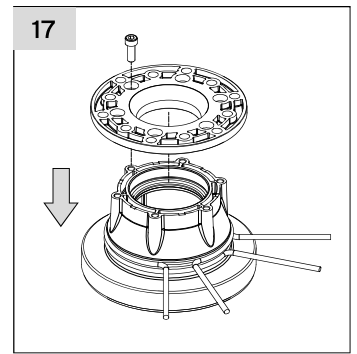
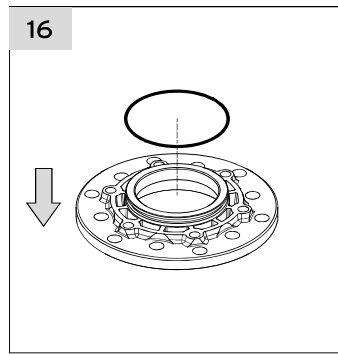
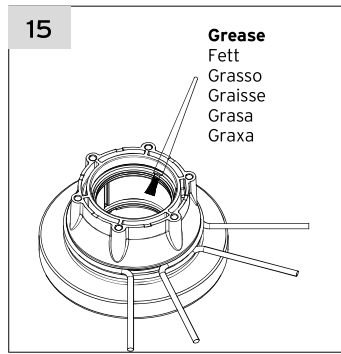
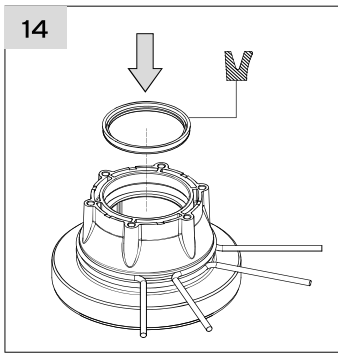

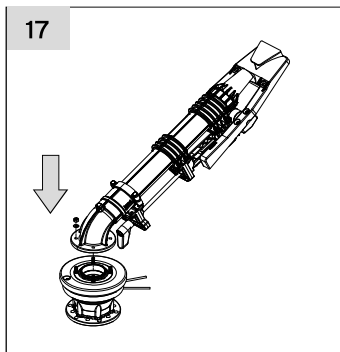
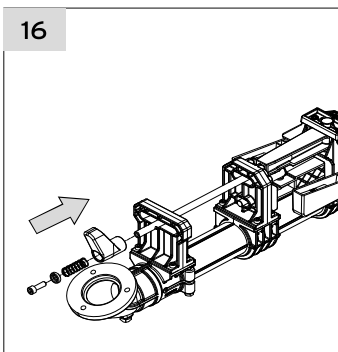
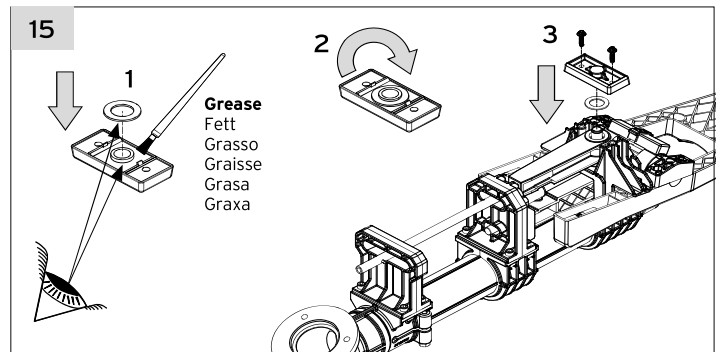
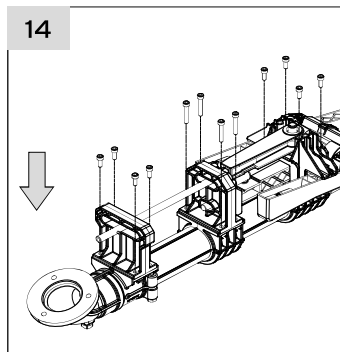
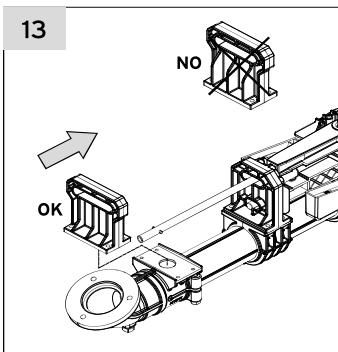
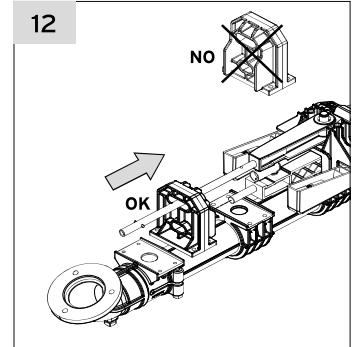
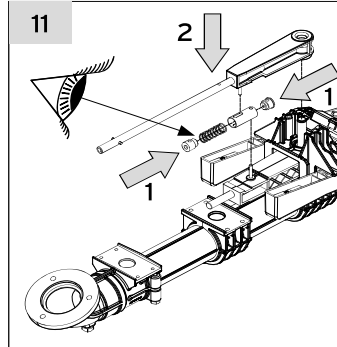
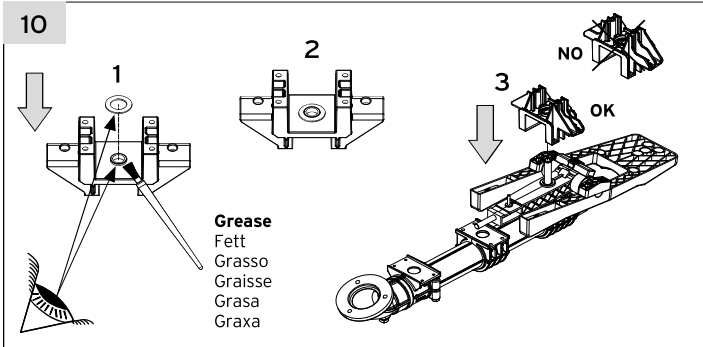
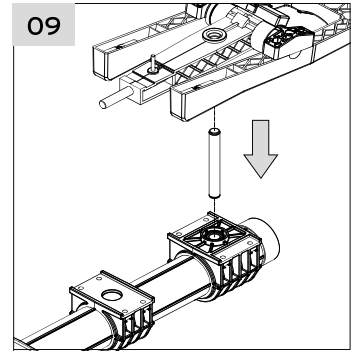
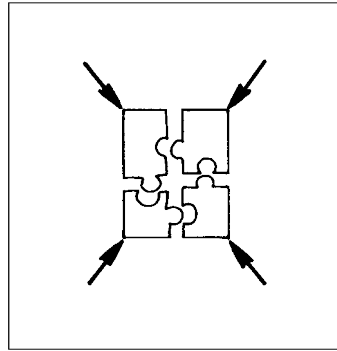
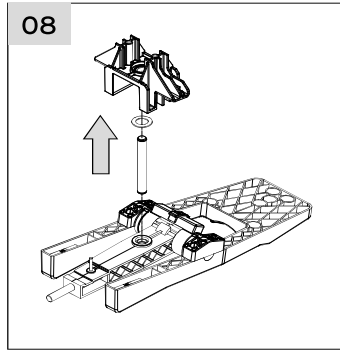
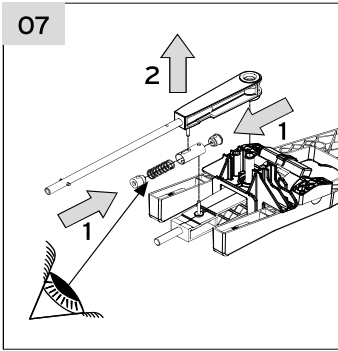

C

Drive arm
Schwingarm
Braccio oscillante
Bras oscillant
Brazo oscilante
Balancim

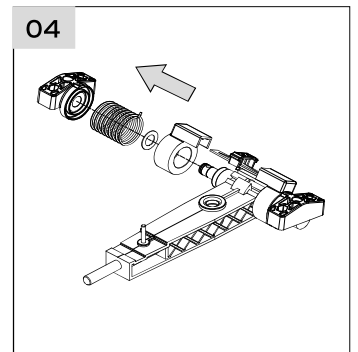
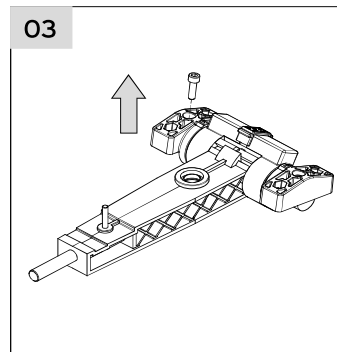
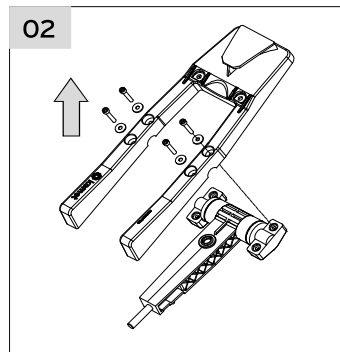
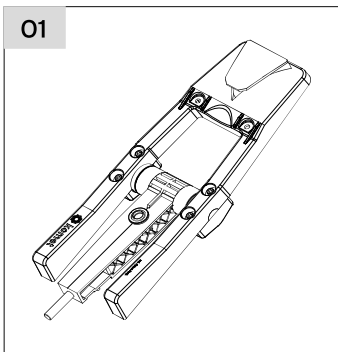
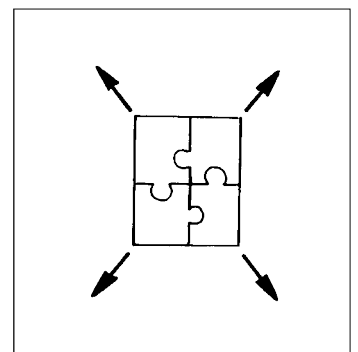

05

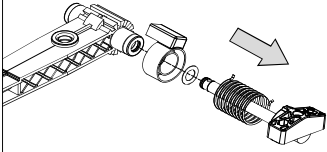

06

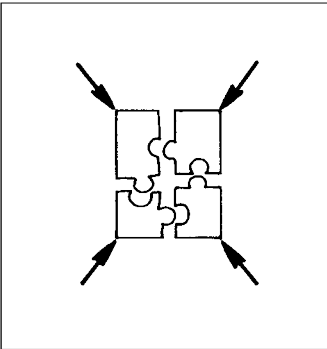
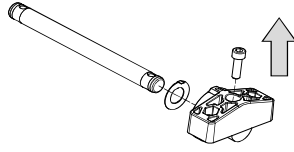

07

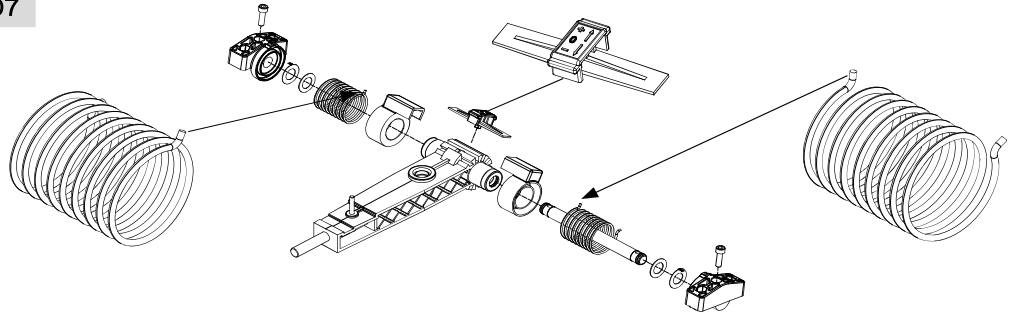

08

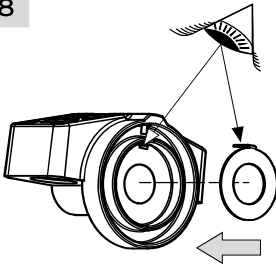

09

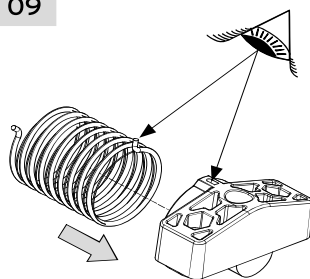

10

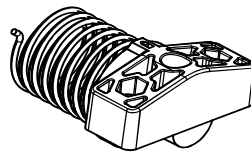

11

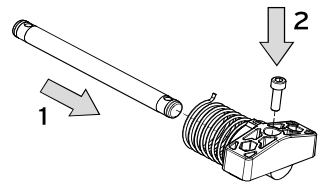

12

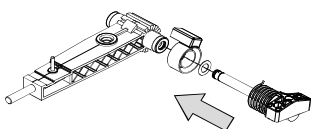

13

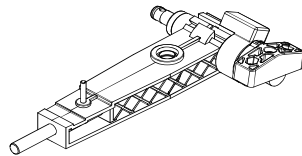

14

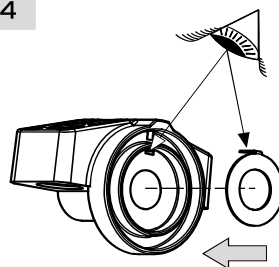

15

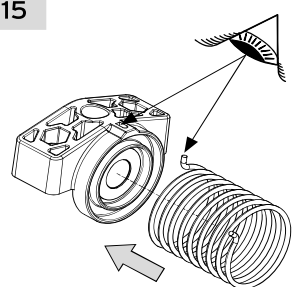

16

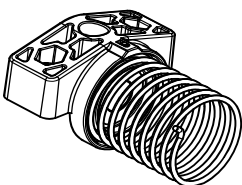

17

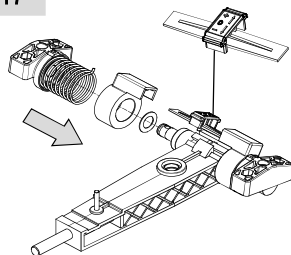

18

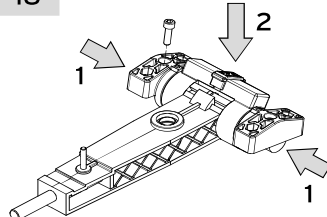

19

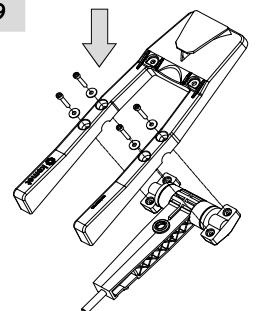

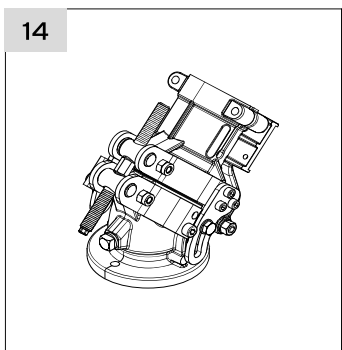
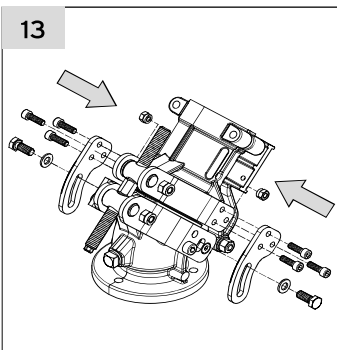
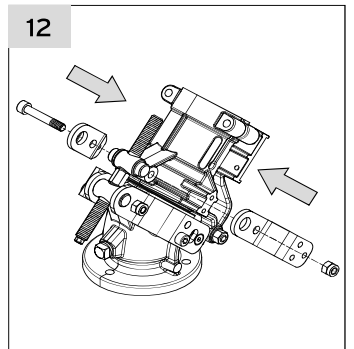
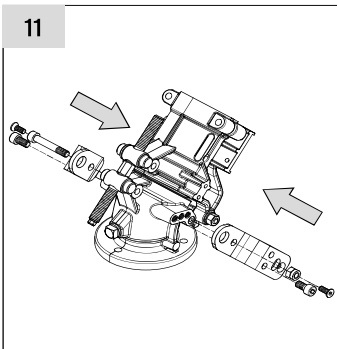
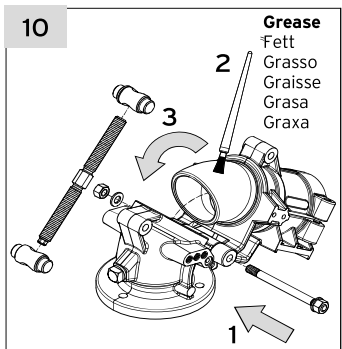
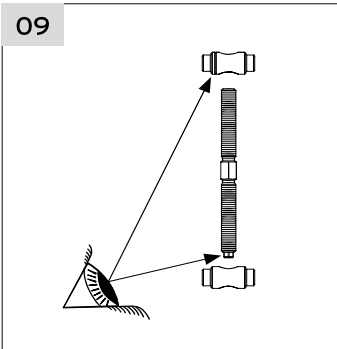
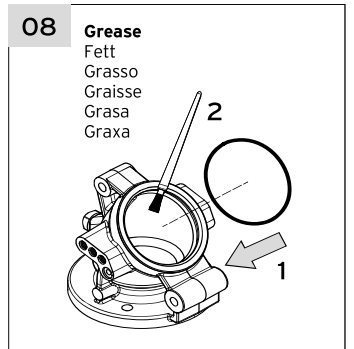
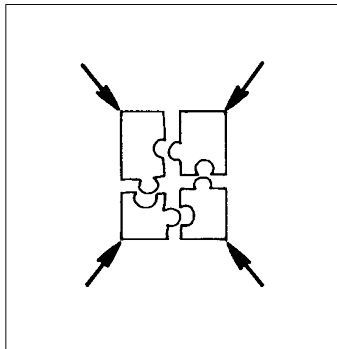
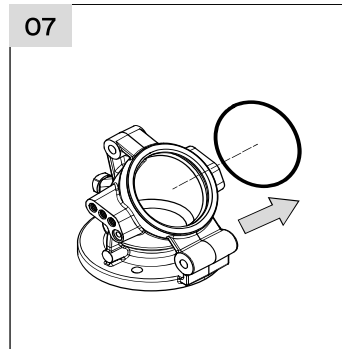
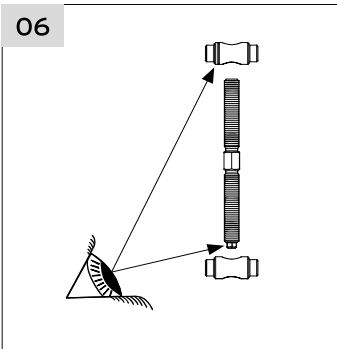
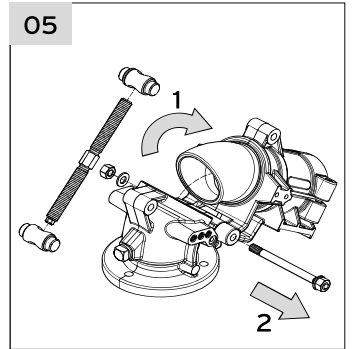
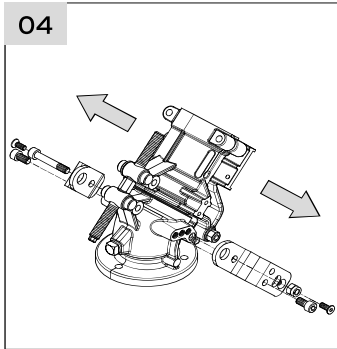
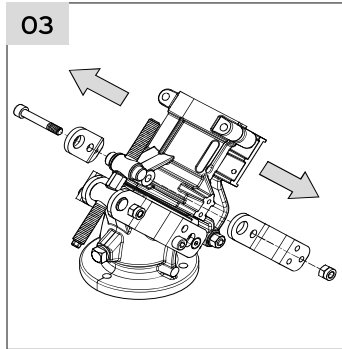
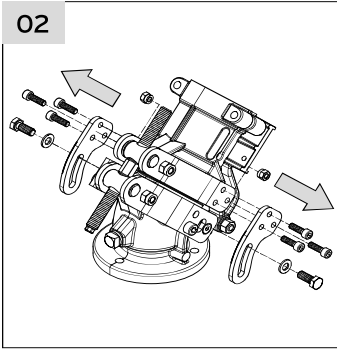
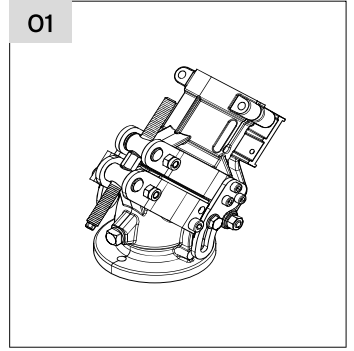
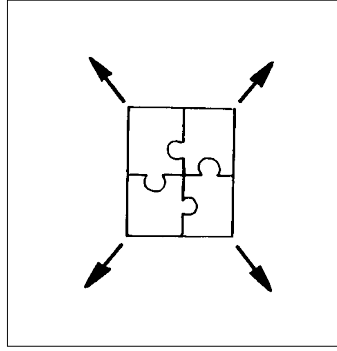
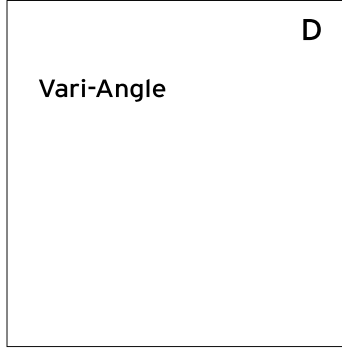
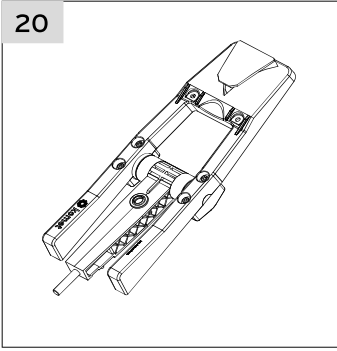

Lock for transport
Transportsicherung
Arresto per trasporto
Fixation pour transport
Bloqueo de transporte
Trava de transporte

